



Yankee Tipper

Cleaning: *Please for the sake of the birds, keep your feeders clean!* Dirty feeders can harm the birds. Clean with a mild dish detergent using a soft brush, sponge or cloth, and rinse thoroughly with water for simple cleaning. **Sanitize:** Rinse with a 50/50 solution of white vinegar and water. Do not soak metal components in the 50/50 solution of white vinegar and water as this may damage the finish. Rinse thoroughly with water. **Dry completely before filling with seed.**

Disassemble for Easy Cleaning or Part Replacement

1. Unscrew the knurled knob from the bottom of the feeder. Remove the lock washer (added in late 2015 to reinforce tray) and the tray.
2. The cable assembly can be removed by turning the lower lip of the cable assembly, which is visible beneath the port, counter clockwise (viewed from the bottom) until the hash mark on the lip of the base assembly lines up with the left hash mark on the port. You will feel a click.
3. Remove the four tube screws to release the tube from the port. The port and silo assembly may be disassembled for easy and thorough cleaning, by removing the three screws located inside the bottom of the port.
4. Remove the cap and bail wire assembly by sliding the cap up the bail wire. Gently pull each end of the bail wire out of the bail rod.
5. Remove the bail rod by laying the tube on a flat surface with the bail rod parallel to the table/floor. Apply pressure to the top of the tube until it becomes oval/oblong in shape to release one side of the bail rod. Reach inside the tube and shimmy the other end of the bail rod out of its hole.

Assemble

1. Install the bail rod by lining the bail rod up with both of the designated holes in the top of the tube. Apply pressure to the outside of the tube at both ends of the bail rod until the tube locks into the grooves in the bail rod.
2. Replace the cap and bail wire assembly by inserting each end of the bail wire into the bail rod, making certain they are fully inserted before sliding the cap back into place on top of the tube.
3. Assemble the port and silo assembly, if you chose to disassemble for easy and thorough cleaning, by placing the silo assembly inside the port. Hold the silo assembly and port upside down and rotate the silo assembly until the three holes in the port line up with the three plastic posts on the silo assembly. Replace the three screws.
4. Install the tube by lining up the four holes in the tube with the four holes in the port and replace the tube screws. **Do not overtighten the screws as this will cause the tube to crack, especially in hot weather.**
5. Install cable assembly by placing it up inside port and aligning any of the three hash marks on the lip of the cable assembly with the left hash mark on the port and turn clockwise (viewed from the bottom) until it clicks into place.
6. Replace the tray on the threaded post of the cable assembly, making certain that the tray is convex (curves slightly downward). Replace lock washer (added in late 2015 to reinforce tray) and knurled knob.

Feeder Placement

- Hang the feeder far enough away from any deck rail, pole, tree, etc. so that the squirrel must place all of its body weight on the tray. The recommended minimum is 14", but a greater distance may be preferable since the mechanism is based on weight. A squirrel that is able to lean across to the feeder by placing only part of its weight on the tray may avoid tipping the tray.
- Red squirrels and chipmunks may not be heavy enough to tip the tray, but placing the feeder so that they have to jump to it will significantly increase your chances of deterring them.
- The Yankee Tipper should be hung in a location where it is sheltered from the wind. Due to the large surface area of the tray, high wind gusts can cause the tray to collapse.

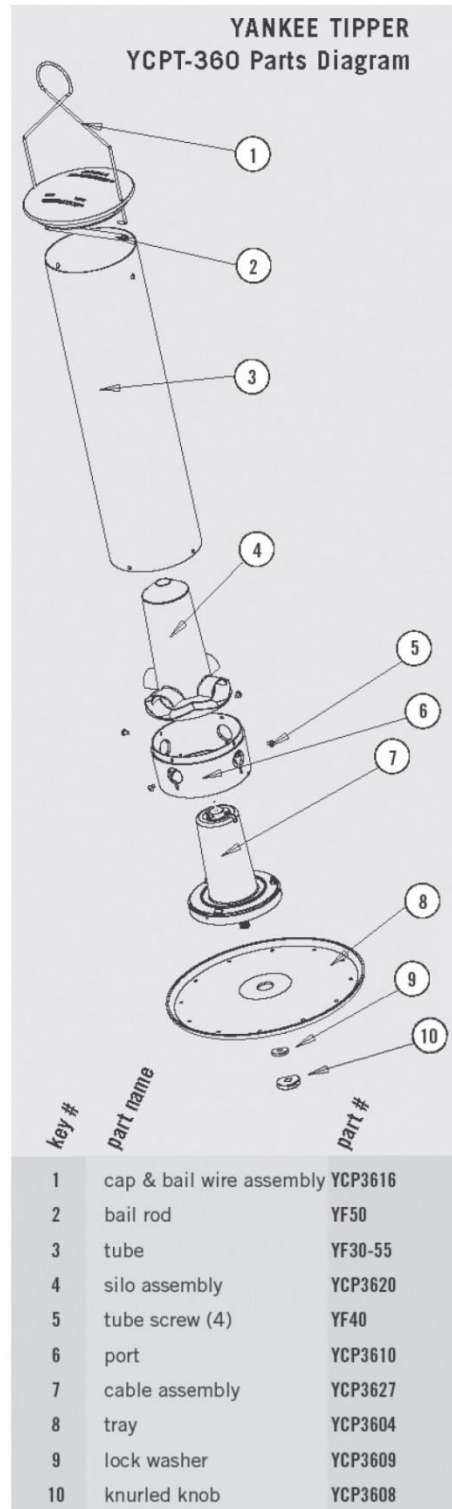

Droll Yankees Inc. • drollyankees.com
 Customer Service: drollbird@drollyankees.com
 (860) 779-8980 or (800) 352-9164